

# INSTRUCTION MANUAL

HF BAND 1.5kW  
AUTO ANTENNA TUNER

**MODEL : HC-1.5KAT**



 **TOKYO HY-POWER**

## Contents

1. Foreword.....	Page 1
2. Features.....	Page 1
3. Cautions.....	Page 2
4. Specifications.....	Page 4
5. Explanations of Front & Rear Panels.....	Page 5
6. Connections (Setting).....	Page 9
7. Operation.....	Page10
1) Initial Status When Power Turned On.....	Page10
2) Operation Mode and Setting Mode.....	Page10
3) Manual Tuning Mode.....	Page11
4) Flow of Operation.....	Page11
5) Conditions for Self Tuning Initiation.....	Page13
6) Menu Map.....	Page14
8. Explanation of Various Functions.....	Page15
9. Technical Information.....	Page17

## 1. Foreword

HC-1.5KAT is an HF high power auto antenna tuner with a maximum power handling capability of 1.5kW.

It works in an auto band set mode when combined with Tokyo Hy-Power Linear amps of HL-1.5KFX and HL-2.5KFX. Also, it features an extremely fast tuning speed of 1 sec. max. in most cases. When the transmitter is keyed, the tuner detects the antenna impedance (resistance and reactance) directly, and two variable capacitors are auto-adjusted so that tuner matches the antenna impedance.

## 2. Features

- High speed and precision tuning due to the high resolution stepping motors: Usually less than one second of tuning time and auto tracking (re-tune) during on air.
- Auto band-set operation with Tokyo Hy-Power HL-1.5KFX and HL-2.5KFX amps: Our original inter-face design for a combined auto operation.  
Linear amps other than those two models can be combined, if band set only is manually made.
- Simple operation: Auto tunes even with ssb/voice as well as keyed codes.  
During the auto-tuning time period linear amp is held at STBY (stand-by), and is automatically turned on to OPER. (operate) as soon as the tuning is completed.
- High power quality components used throughout such as 3 kV air variable capacitors and power relays.
- There are three antenna ports of SO-239 provided that can be programmed to the specific operating bands as desired.  
Also these ports may be programmed "Thru (through)", as needed to by-pass the tuner network.
- Pre-set positioning system is incorporated to set the initial variable capacitors positions at mid points of respective frequency bands.  
This makes the tuning time relatively fast and more advantageous.
- "Forced tune" function is incorporated.  
As you move the frequency on the radio, auto-tuning may or may not be initiated.  
If the exact tuning is desired in such a case, forced tuning is available by pressing the SELECT dial knob.

### 3. Cautions

Note the followings for the safety of the operator.

- A If any smoke, odor, or fire is detected, take the following steps for safety.

Cease the transmission.

Turn off the power of linear amp and radio.

Turn off the power of tuner.

- B High RF Voltage

A high RF voltage is generated during the transmission period.

- Never remove the top cover.
- Never operate without connecting an antenna.
- Never touch RF connectors.
- Be careful of the tuner cabinet as it may bear RF voltage depending on the antenna type connected.
- Those operators with heart pacemaker must not approach the tuner.
- Avoid the risk of RF burn from a high SWR antenna. Long wire antenna generates an extremely high RF voltage depending on its element length.
- Never touch cooling fan inside as well as L, C components as they generate much heat during operation.

- C Limited Application

This tuner is designed for the use of the amateur radio station operated by qualified operator. Application for other than designed purpose leads to the failure of the device and/or the severe damage to the surrounding devices.

Never exceed the maximum handling power of 1.5kW.

- D Setting

Internal parts such as tuning coils and motors are forced air cooled and need air ventilations. Keep at least a few inches of space from the rear wall, and a space of rubber feet height at the bottom.

Keep out of direct sun light, in a clean dry environment.

- E Power Derating for High SWR Antenna

When the antenna has high SWR of 3 to 4, reduce RF output power by at least a half not to damage the tuning components.

Also never attempt to tune to very high SWR antenna, even if the tuner happens to work, or the tuning relays and capacitors will be severely damaged.

- F Order of Turning Powers On

It is recommended to turn on in the order of transceiver at first, then linear, and the

auto tuner.

G 50MHz (6m)

The tuner does not cover 6m band.

When combined with HL-1.5KFX amp, "50MHz BAND THRU" is displayed on LCD panel for the band selection of 50MHz with HL-1.5KFX.

H 1.8 and 3.5 MHz Bands

These bands are divided into three segments as follows;

160m.....1.8, 1.9, 2.0

80m.....3.5, 3.8, 4.0

Depending on your operation, you can program your favorite segments into memory.

(This helps reduce the loads of tuning elements of the network.)

I. Power Off/Thru

When the POWER switch is turned off, "IN" (coax input from the linear) is by-passed to ANT1 port.

## 4. Specifications

### Model HC-1.5KAT Specifications

Parameter	Description	Remarks
Frequency Range	1.8-29.7 MHz	
Output Impedance Range	12.5-200 (*16.6-150 )	*Reduced range on 1.8, 3.5 and 28 MHz.
Maximum Handling Power	1.5 kW (P.E.P./CW)	RTTY 1kW
Input Impedance	50	
Tuning Power	50 W (80W max.)	
Tuning Time	1 sec. (typ.)	
	2.5 sec. (max.)	Under typical worst SWR condition
	4.0 sec. (max.)	Under absolute worst SWR condition
DC Power Voltage	DC 12 V - 14 V	From external DC power supply (Power supply not included.).
Current Drain	1.5 A max.	
Quiescent Current	0.7 A	
DC Power Polarity	Negative ground	
Display	LCD Module	
Operating Temp. Range	0 deg. to +40 deg. C	
VSWR (Max.)	1.5 (typ.) or lower	After tuning
Circuit Type	T-shaped	
Driving Motors	Stepping Motors for Two Air Variable Capacitors	0.25 deg. resolution/step
L Changes	Relays to short	
Matching Algorithm	Analog Control with MPU	Phase and  Z  Magnitude Detected
Dimension	200 x 140 x 300 mm (W x H x D)	Approx. 8 x 5.6 x 12 inches
Weight	Approx. 5 kg, or 11 lbs.	
Input Connector	SO-239 (UHF)	
Output Connectors	Three SO-239's	
Cooling	Partial air forced cooling fan	
Accessories	DC power cable with 3.5 mm dia. plug (4 feet)	
	Band control cable with DIN 7 pin plugs	To connect to THP amps.
	PTT Out cable with RCA plugs	To connect to amps.

## 5. Explanations of Front and Rear Panels

### <FRONT PANEL>

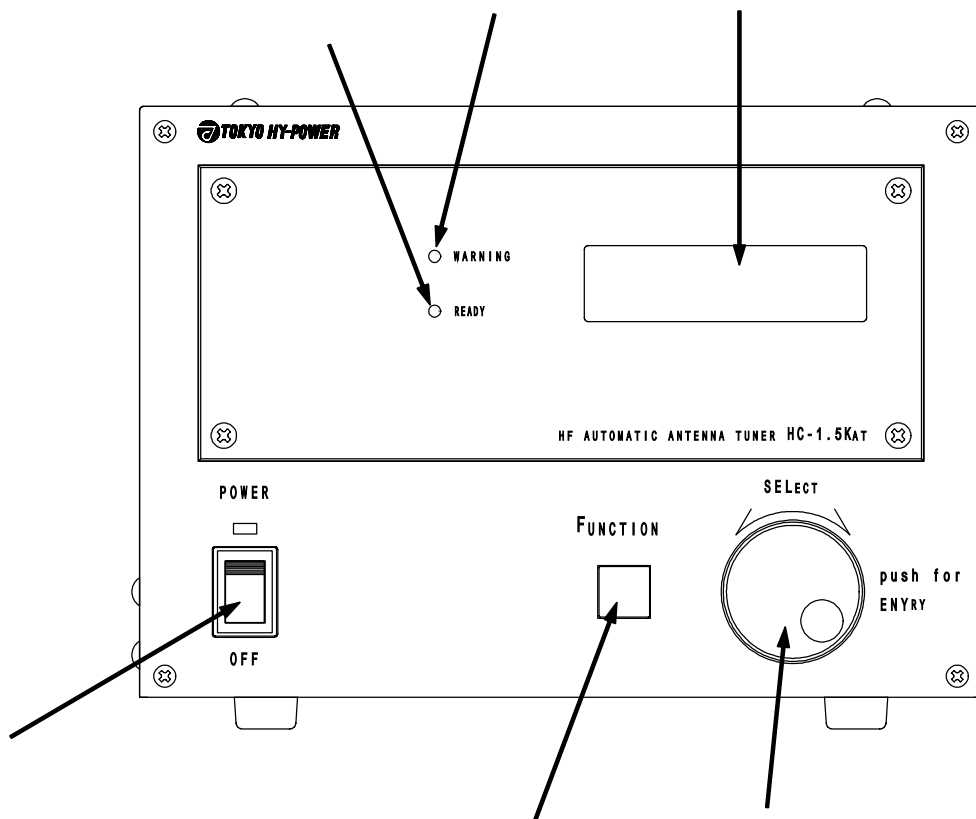

#### POWER

Power switch to turn on and off.

When turned off, the tuner becomes “through” state, leaving tuning network out of the antenna feeder.

#### FUNCTION

Function button to call for operation menu.

(See 7. 2)Operation Mode and Setting Mode at page10)

#### SElect / Push for ENTRy

Complex dial of setting dial (rotating) and entry (determination push button) to set various mode functions and parameters.

Turn to set BAND (freq. band) and ANT/THRU (antenna) ports.

Press to go out of exit (to AUTO mode), after either BAND or ANT/THRU setting is finished.

Also press to change C<sub>1</sub> and C<sub>2</sub> positioning during manual tuning mode.

LCD (Display)

Panel to display various status of operation.

LED Lamp / Warning (Orange)

Lights when the tuning is made at critical conditions of L and C.

Blinks to indicate tuning failure. (Press "FUNCTION" key to reset.)

LED Lamp / Ready (Green)

Lights when auto-tuning is completed and the system is ready.

Blinks when tuning is not finished and/or tuner is waiting for RF drive to initiate auto-tune process.

## <REAR PANEL>

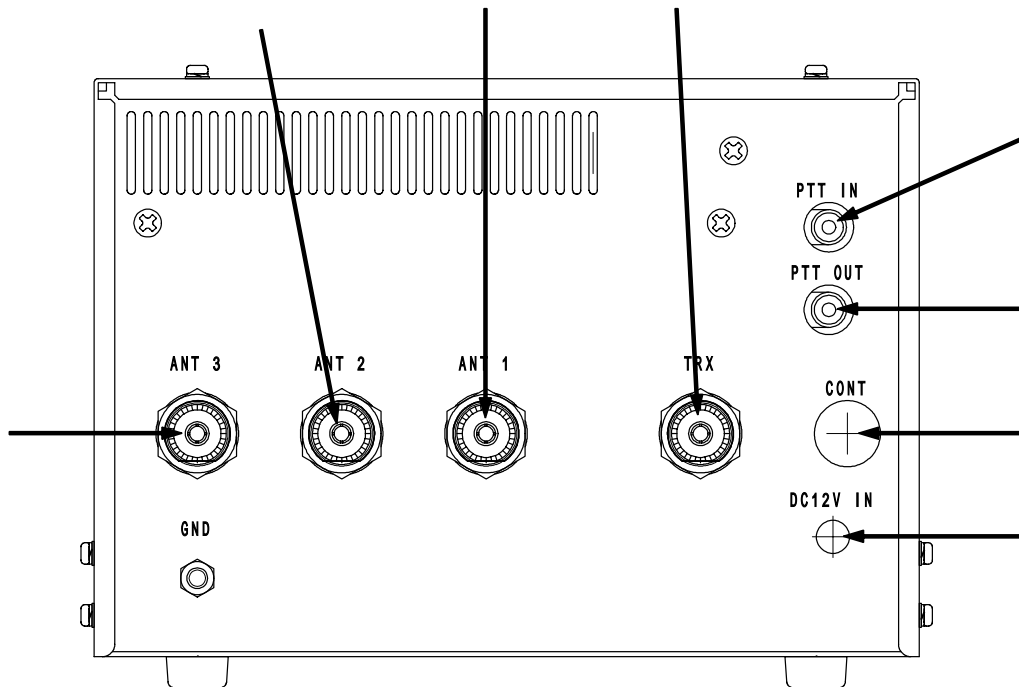

### DC12V

DC input jack to connect external power supply of DC12 V (11 - 14V / 1.5 A).

### CONT

DIN Socket (7 pin) to connect a control cable from "TUNER" of HL-1.5KFX or HL-2.5KFX.

### PTT OUT

Phono jack to connect PTT cable to SEND (or STBY, REMOTE) socket of linear amp.

### PTT IN

Phono jack to connect PTT cable from SEND (or TX GND, REMOTE, RELAY etc.) socket of transceiver.

### TX

SO-239. Connect a coax jumper cable from the ANT (antenna) connector of the linear amplifier.

### ANT -1, -2, -3

SO-239. Connect a coax cable from the antenna.

## <Explanations of LCD Display>

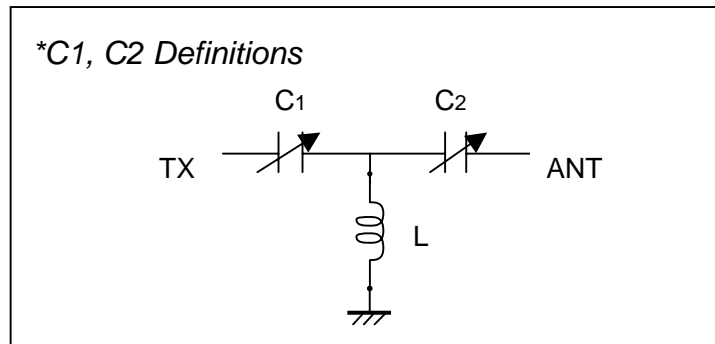
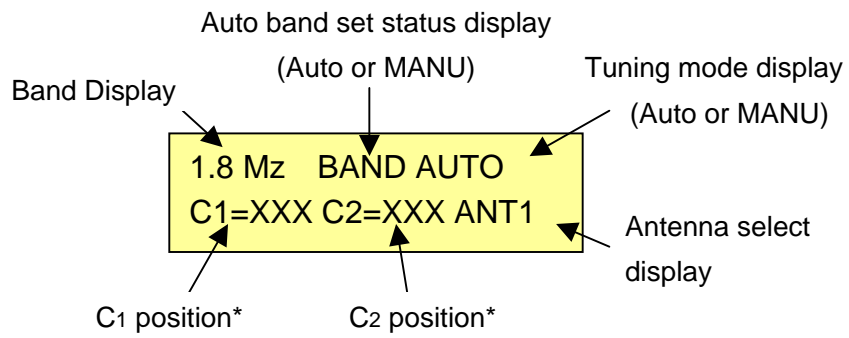

## 6. Connections (Setting)

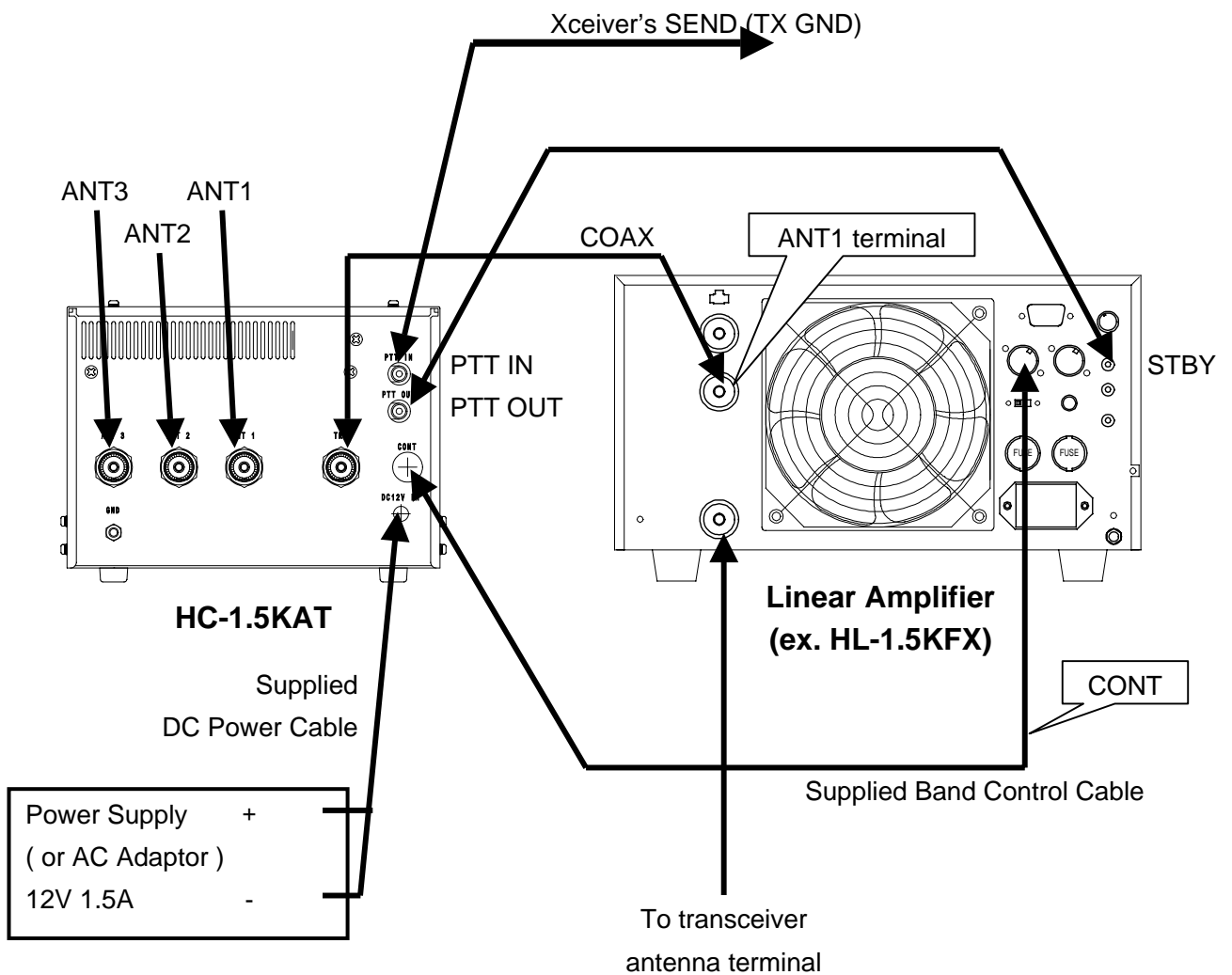

\*For other connections of the Linear Amplifier, please refer to the amplifier's manual.

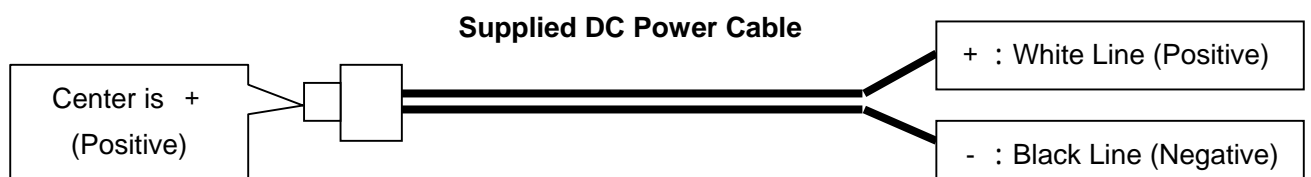

## 7. Operation

### 1) Initial Status When Power Turned On

Fig.1 is initially displayed for a second after the power is ON. Then Fig.2 is displayed, where 1.8Mz ant ANT1 are default.

(Note: Other than 1.8Mz may be displayed if Band Control Cable is connected to the amplifier or if the tuner has been once operated after the purchase.)

<Fig1>

```
HC-1.5K AT VerXX
TOKYO HY-POWER
```

<Fig2>

```
1.8 Mz  BAND AUTO
C1=XXX C2=XXX ANT1
```

### 2) Operation Mode and Setting Mode

Operation Mode is a status waiting for RF drive, i.e. auto tuner is ready to work. <Fig2> LCD displays Fig.3 at this time.

If **Function** button is pressed one time or more, Operation Mode changes to Setting Mode. <Fig4, 5 and 6>

<Fig3>

```
Xxx Mz  BAND AUTO
C1=XXX C2=XXX ANTx
```

(X is a value actually set for the specific band.)

Setting Mode is a mode to set band, and antenna selections as well as C1/C2 positions of manual tuning.

During this mode, auto tuning can not be accepted if the transmitter is keyed.

<Fig4>

```
>Xxx Mz  MANU FUNC
C1=XXX C2=XXX ANTx
```

*To Select Band*

<Fig5>

```
Xxx Mz  BAND FUNC
C1=XXX C2=XXX>ANTx
```

*To Select ANT*

<Fig6>

```
Xxx Mz  BAND MANU
C1>XXX C2=XXX ANTx
```

*C1/C2 positions of Manual  
Tuning Mode*

“ > ” mark is displayed at this time to urge the setting of Band, Ant, and C1/C2 respectively.

If ANT (antenna) is selected as desired, press FUNCTION button twice, and you can return to AUTO tuning mode (or Operation Mode).

### 3) Manual Tuning Mode

After the ANT (antenna) selection is finished, you may enter the manual tuning mode by pressing FUNCTION button one more time.

<Fig6> shows a status where you can manually tune C<sub>1</sub> by SELECT dial.

Then pressing the SELECT dial, prompt ( > ) sign shifts to C<sub>2</sub> (C<sub>2</sub> > XXX), and you can tune C<sub>2</sub> by dial.

C<sub>1</sub> and C<sub>2</sub> must be reciprocally changed to tune for minimal SWR (or Pr) on SWR/PWR meter.

If the minimal SWR (or Pr/ reflected power) is obtained, you may start to transmit with full power.

(Note: Auto band set will not track at Manual Tuning mode, if you change the band of radio.)

### 4) Flow of Operation

To set the BAND: If your tuner is connected to HL-1.5KFX and/or HL-2.5KFX with a supplied band control cable, skip this step and go to (To set the ANT selection).

If the amplifier is other than two models above of Tokyo Hy-Power Labs., you need to set the BAND manually as follows;

Press **Function** button once. On LCD, “ > ” mark is displayed and requests you to further put in the data.

<Fig7>

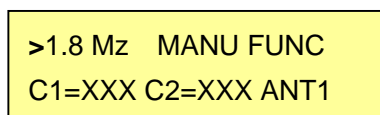

>1.8 Mz MANU FUNC  
C1=XXX C2=XXX ANT1

Turn **Select** dial to the desired band of operation.

Press **ENTry** dial and tuner will be back to Operation Mode. If above setting is finished, motors will run to drive variable capacitors to the respective pre-set positions.

“WAIT” is displayed just for a short period, until the pre-setting finishes. <Fig8>

<Fig8>

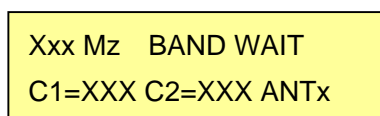

Xxx Mz BAND WAIT  
C1=XXX C2=XXX ANT<sub>x</sub>

To set the ANT selection:

Program the desired antenna system to the current BAND being displayed, as follows;

Press Function button twice, (if you are in Operation Mode), so that “ > ” sign appears in front of ANT<sub>x</sub>. <Fig9>

<Fig9>

```
Xxx Mz  BAND FUNC
C1=XXX C2=XXX>ANTx
```

Turn **Select** dial to select the antenna (1, 2, or 3) and/or thru (1, 2, or 3).  
Press **Function** button to finish this setting to return to Operation Mode.

Manual Tuning

You can enter the manual tuning mode (to tune C<sub>1</sub>/C<sub>2</sub> variable capacitors manually) following the above step of ANT selection.  
(See 7.3)Manual Tuning Mode at page11.)

To key radio/amp to auto tune:

There are two options to auto-tune the HC-1.5KAT.

A is the safest method not to damage the amp or tuner in any case.

B is the easier way but “Reflected Power Prot” of linear amp may trip occasionally.

A. Switch the amplifier to STBY (Stand-By) position. Starting from Operation Mode, drive a carrier (CW) voice/SSB signal of approximately 50 W (80 W max.), and the tuning will start automatically. See Fig10. Tuning will be finished within a second or so in most cases. LCD displays Fig11. At this point, you may adjust RF Power level of your radio to fully drive the amplifier.

<Fig10>

```
Xxx Mz  BAND TUNE
C1=XXX C2=XXX ANTx
```

*“TUNE” indicates now tuning.*

<Fig11>

```
Xxx Mz  BAND AUTO
C1=XXX C2=XXX ANTx
```

*Tune completed, AUTO displayed*

B. Look for the vacant frequency channel not to interfere with other stations.

Switch the amplifier to OPER (operate) position, and drive a signal of any mode (CW, SSB/voice, RTTY etc.) with 50W (80W max.) from the radio.

Then the tuner will automatically start to tune in STBY (stand by) mode of amplifier.

When the tuning is finished, tuner will issue the command to the amplifier to switch to OPER position.

\*Note1. When the tuner fails to tune, reduce the drive power and reset the FUNCTION button. Antenna may have a critically high SWR of 4.0 or more.

\*Note2. Linear amp may trip with high reflected power protection while tuning. Reset the amp, and complete the tuning step.

To start full power transmission:

Even if the tuner is once tuned, it will automatically try to re-tune, when SWR becomes approximately 1.5 or higher during transmission.

(Caution: This tuner is designed to automatically track the change of SWR. However, if the sudden sharp SWR change is expected in such an occasion as when the transmitting frequency is swept from one band edge to the other, be sure to re-tune with the amplifier in Stand-By mode, or reset the amplifier to finish the auto tuning if Pr prot has tripped during tuning process.)

## 5) Conditions for Self Tuning Initiation

Self auto tuning is not initiated, unless any one of the following condition is satisfied.

- a. Matching status has deviated out of SWR=1.5
- b. Forced tuning button () has been pressed.

## 6) Menu Map

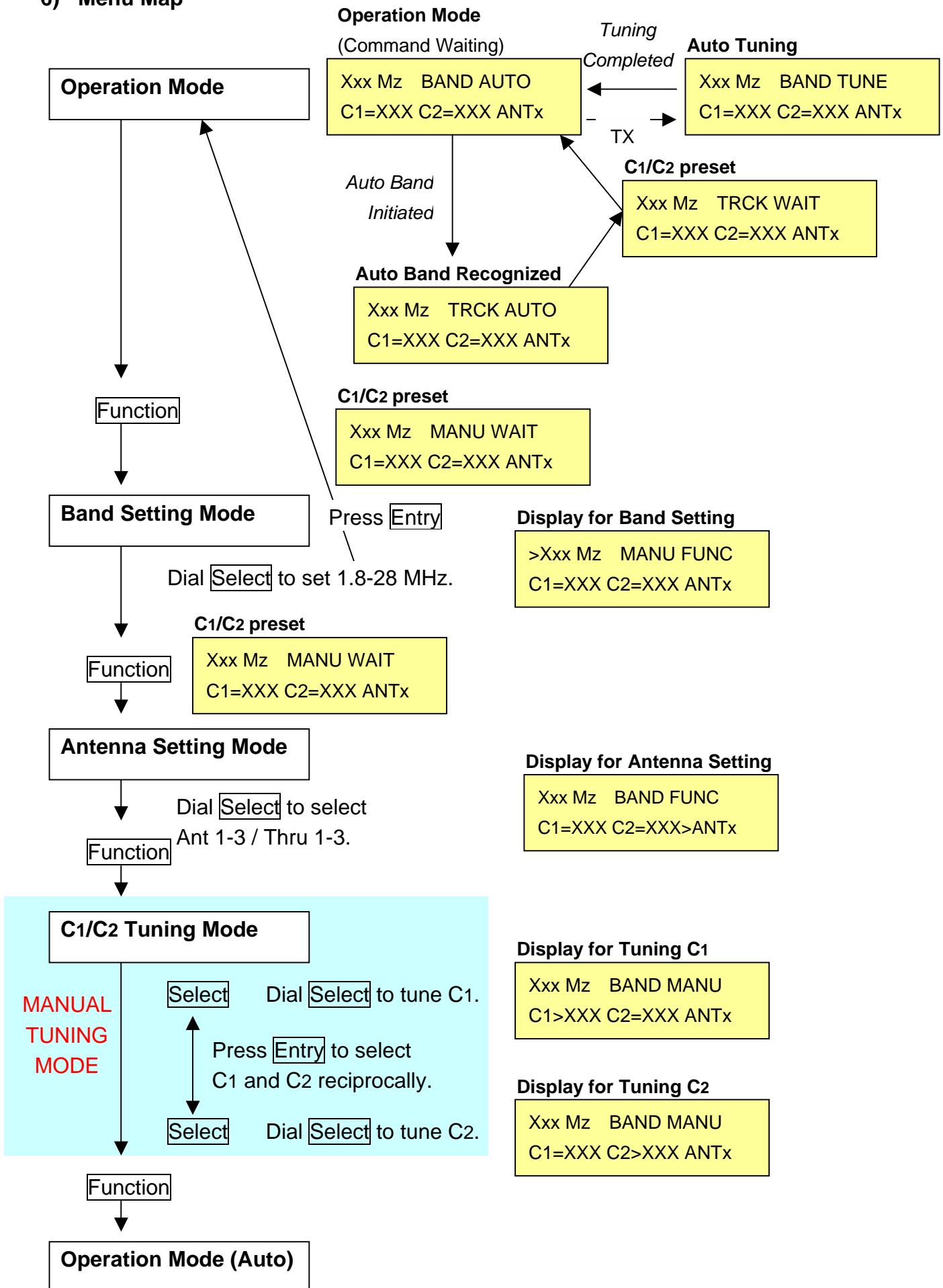

## 8. Explanation of Various Functions

### 1) Manual Tuning

Tuner is manually tunable as needed.

Press **Function** three times when in Operation Mode.

Press **Entry** to select either C1 or C2 reciprocally. (See Fig 12, Fig13)

Drive a CW/RTTY carrier (50W to 80W) from radio.

Turn **Select** dial for C1 and C2 so that SWR (or PR) meter deflection gets minimal.

And now you are ready to be on air.

<Fig12>

```
Xxx Mz  BAND MANU
C1>XXX C2=XXX ANTx
```

<Fig13>

```
Xxx Mz  BAND MANU
C1=XXX C2>XXX ANTx
```

Note: SWR/Power meter should be connected between the amplifier and the tuner.

C1/C2 positions should be recorded for future reference, as needed.

To return to Operation Mode (Auto), simply press **Function**.

Minimum and maximum capacitances of C1 and C2 are 15 pF and 200 pF respectively.  
LCD panel display of 0 ~ 99 corresponds to 15 pF ~ 200 pF respectively.

### 2) Forced Tuning

This is a function to initiate auto re-tuning, in case SWR value gets slightly worse in transmission (TX) mode.

Press **Entry** button.

3) Collaboration with HL-1.5KFX/ HL-2.5KFX

Connecting the band control cable, "EVENT" and "FREQ" data are communicated between the amplifier and the tuner.

Note: "BAND" changes to "TRCK" (track), while amplifier is sending a new data to the tuner.

It changes back to "BAND" upon finishing the band change.

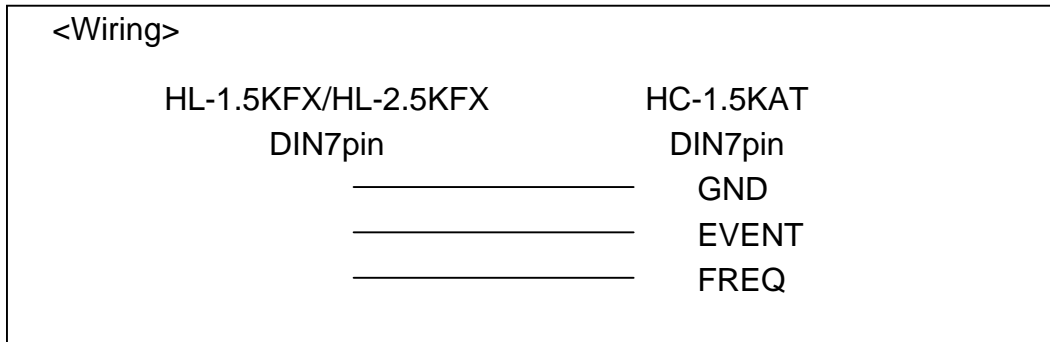

FREQ data: Freq. data signal is sent to tuner.

EVENT signal: When tuner is pre-setting or auto-tuning, this signal is emitted for the amplifier to become through state.

## 9. Technical Information

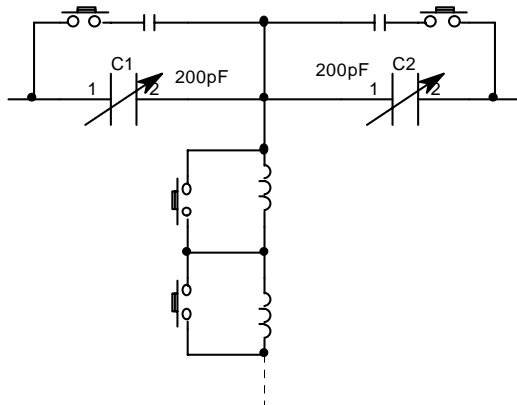

C1, C2 = 200 pF max, 3 kV  
 L = Switched by relays  
 Fixed C = Mica caps., 3 kV

- Tuner circuit is a T-shaped network.
- Series of coils are switched in and out to match antennas of SWR up to 4:1.
- Fixed value caps are added on 1.8 and 3.5 MHz.

### Min/Max C1, C2 positions displayed and pre-set positions

Freq MHz	Fixed C pf	C1		C2		C1 Pre-set LCD	C2 Pre-set LCD
		min LCD	max LCD	min LCD	max LCD		
1.85	200	0	99	0	99	34	34
3.5	150	0	99	0	99	47	44
7.1		32	94	32	94	52	48
10		21	83	21	83	38	36
14.2		13	51	13	51	23	21
18.1		8	35	8	28	16	13
21		6	29	6	25	13	10
24.9		10	27	9	27	16	13
29		2	18	1	18	7	5



#### TOKYO HY-POWER LABS., INC.

1-1 Hatanaka 3-chome, Niiza,  
 Saitama 352-0012 JAPAN  
 Phone: +81(48)481-1211 / Fax: +81(48)478-7453  
 Email: info@thp.co.jp  
 Web: <http://www.thp.co.jp/>

#### TOKYO HY-POWER LABS., INC.-USA(USA Office)

28301 Tomball Pkwy #500-210  
 Tomball, Texas 77375  
 Phone: 713-818-4544  
 Email: thpsupport@airmail.net

(H20, 04, 22)